

EXAMPLE 1

TOP VIEW

STORAGE POS04
LANDSCAPE ONLY - PREPARED FOR PORTRAIT
N° OF SLABS:
 2 CM -> 492
 3 CM -> 328

STORAGE POS05
LANDSCAPE ONLY - PREPARED FOR PORTRAIT
N° OF SLABS:
 2 CM -> 984
 3 CM -> 656

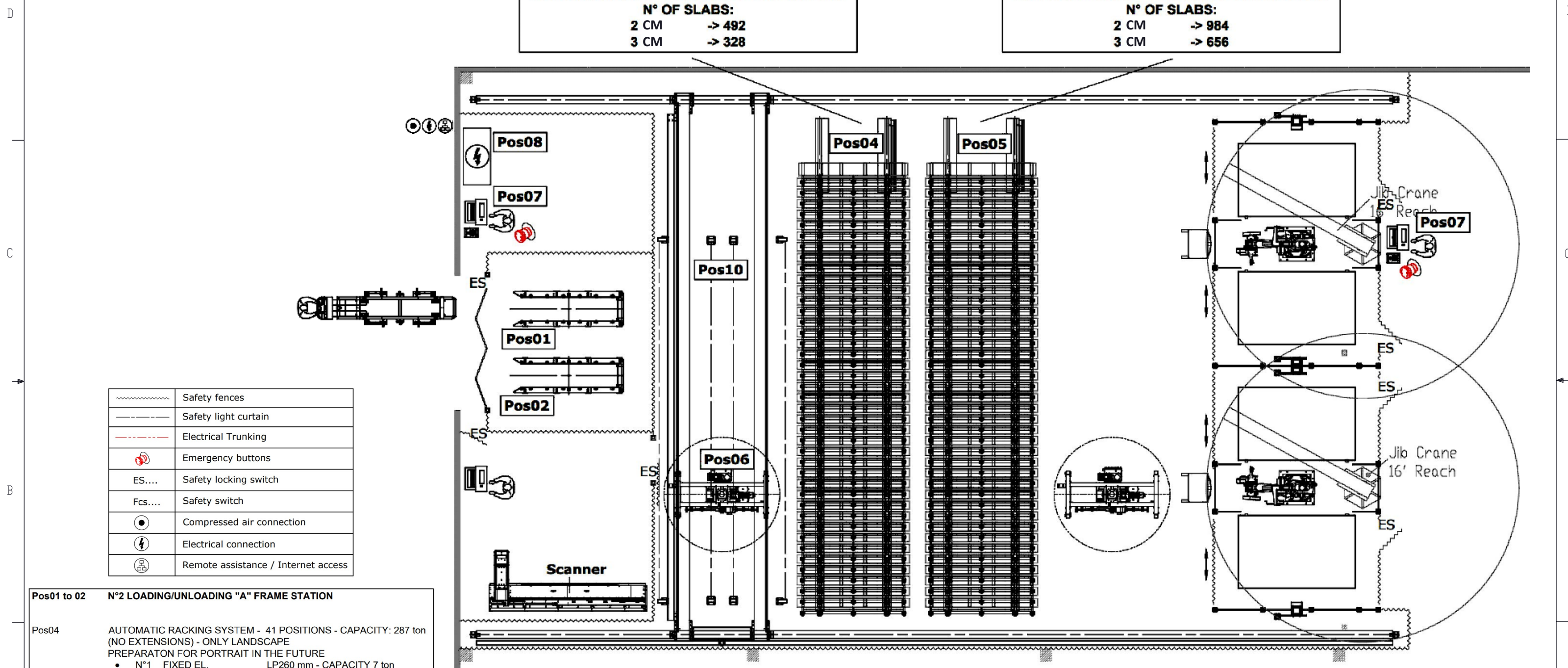

	Safety fences
	Safety light curtain
	Electrical Trunking
	Emergency buttons
	Safety locking switch
	Safety switch
	Compressed air connection
	Electrical connection
	Remote assistance / Internet access

- Pos01 to 02** N°2 LOADING/UNLOADING "A" FRAME STATION
- Pos04** AUTOMATIC RACKING SYSTEM - 41 POSITIONS - CAPACITY: 287 ton (NO EXTENSIONS) - ONLY LANDSCAPE PREPARATION FOR PORTRAIT IN THE FUTURE
 - N°1 FIXED EL. LP260 mm - CAPACITY 7 ton
 - N°39 MOVEABLES EL. LP260 mm - CAPACITY 7 ton
 - N°1 MOTORIZED EL. LP260 mm - CAPACITY 7 ton
- Pos05** AUTOMATIC RACKING SYSTEM - 41 POSITIONS - CAPACITY: 287 ton (NO EXTENSIONS) - 2x 3x PORTRAIT PREPARED
 - N°1 FIXED EL. LP260 mm - CAPACITY 7 ton
 - N°39 MOVEABLES EL. LP260 mm - CAPACITY 7 ton
 - N°1 MOTORIZED EL. LP260 mm - CAPACITY 7 ton
- Pos08** AUTOMATIC 6 AXIS "PREDATOR" CRANE W/RAILS
- Pos07 to 08** N°2 CONTROL PANEL + PC STATION "STOREVOLUTION"
- Pos09** E-CABINET
- Pos10** 4X EDGE ALIENMENT DETECTION SENSORS

*Automated Slab Handling systems are Fully Customizable



PROPRIETARY AND CONFIDENTIAL. THE INFORMATION CONTAINED IN THIS DRAWING IS THE SOLE PROPERTY OF BACA SYSTEMS. ANY REPRODUCTION IN PART OR AS A WHOLE WITHOUT THE WRITTEN PERMISSION OF BACA SYSTEMS IS PROHIBITED.

DRAWN BY: MN	CHECKED BY: TR
DESC: Automated Slab Handling - Layout	
Job No: -----	REV: L-1.01
SIZE: B	SCALE VARIES
3/15/2024	SHEET 1 OF 4

EXAMPLE 1

AUTOMATIC CLASSIFIER
LOADING/UNLOADING

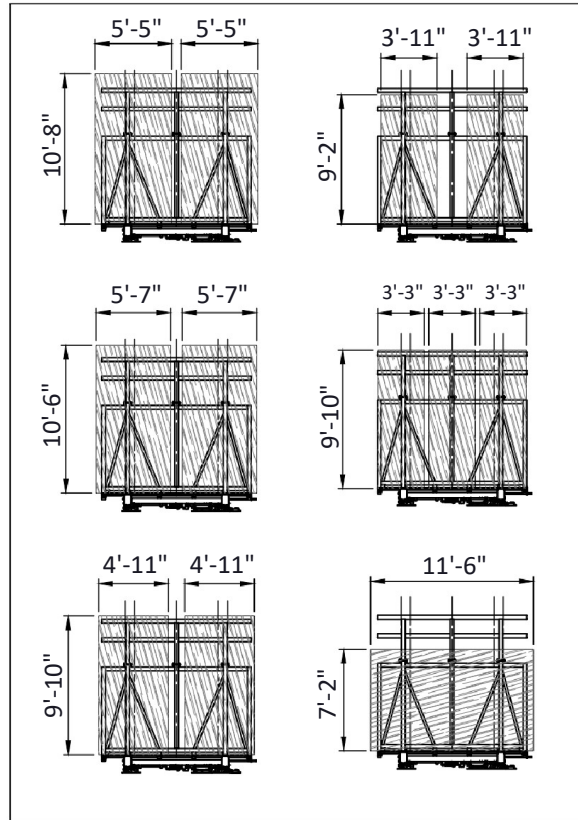

MIN. REMANANT PLATE

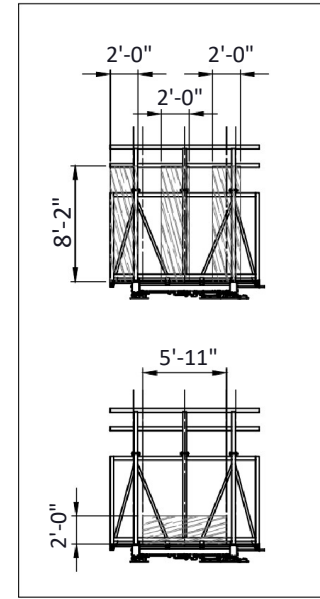

FRONT VIEWS

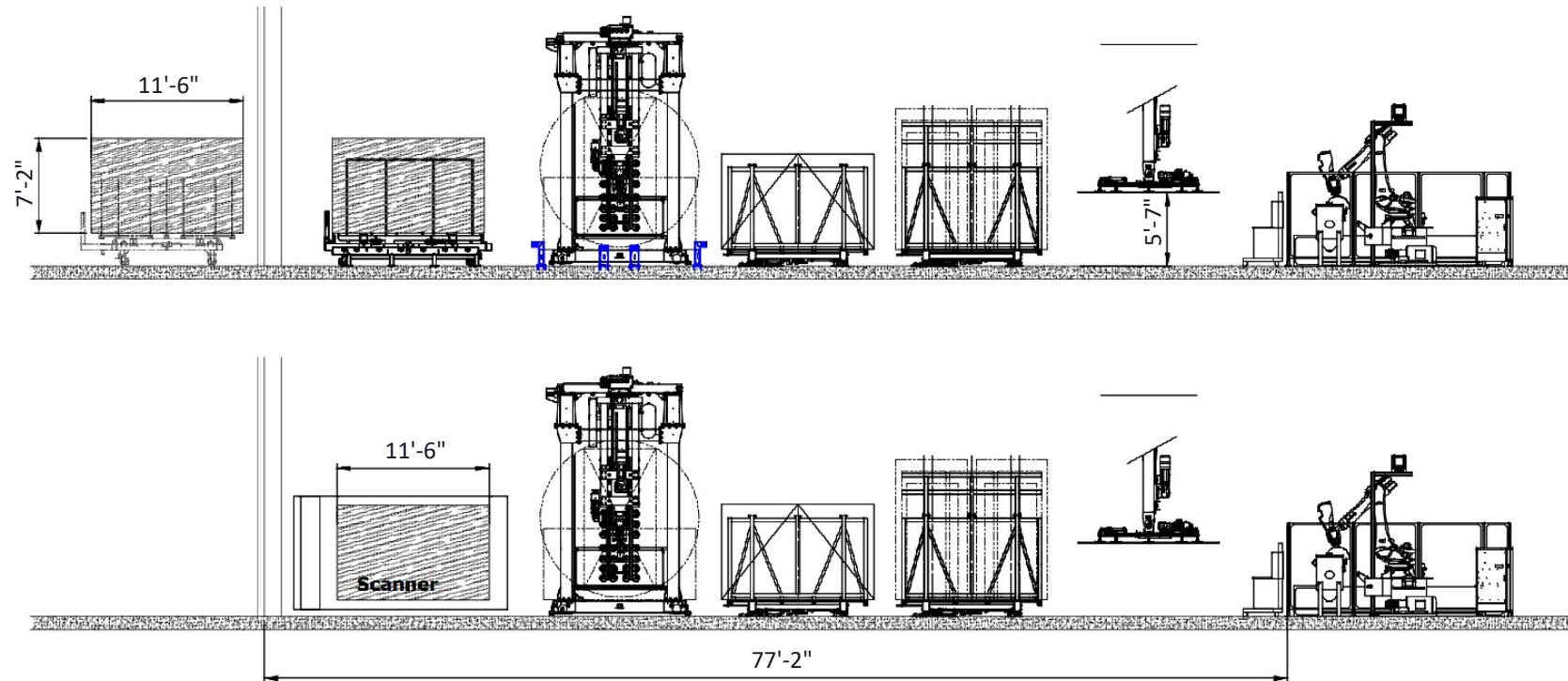

SIDE VIEWS

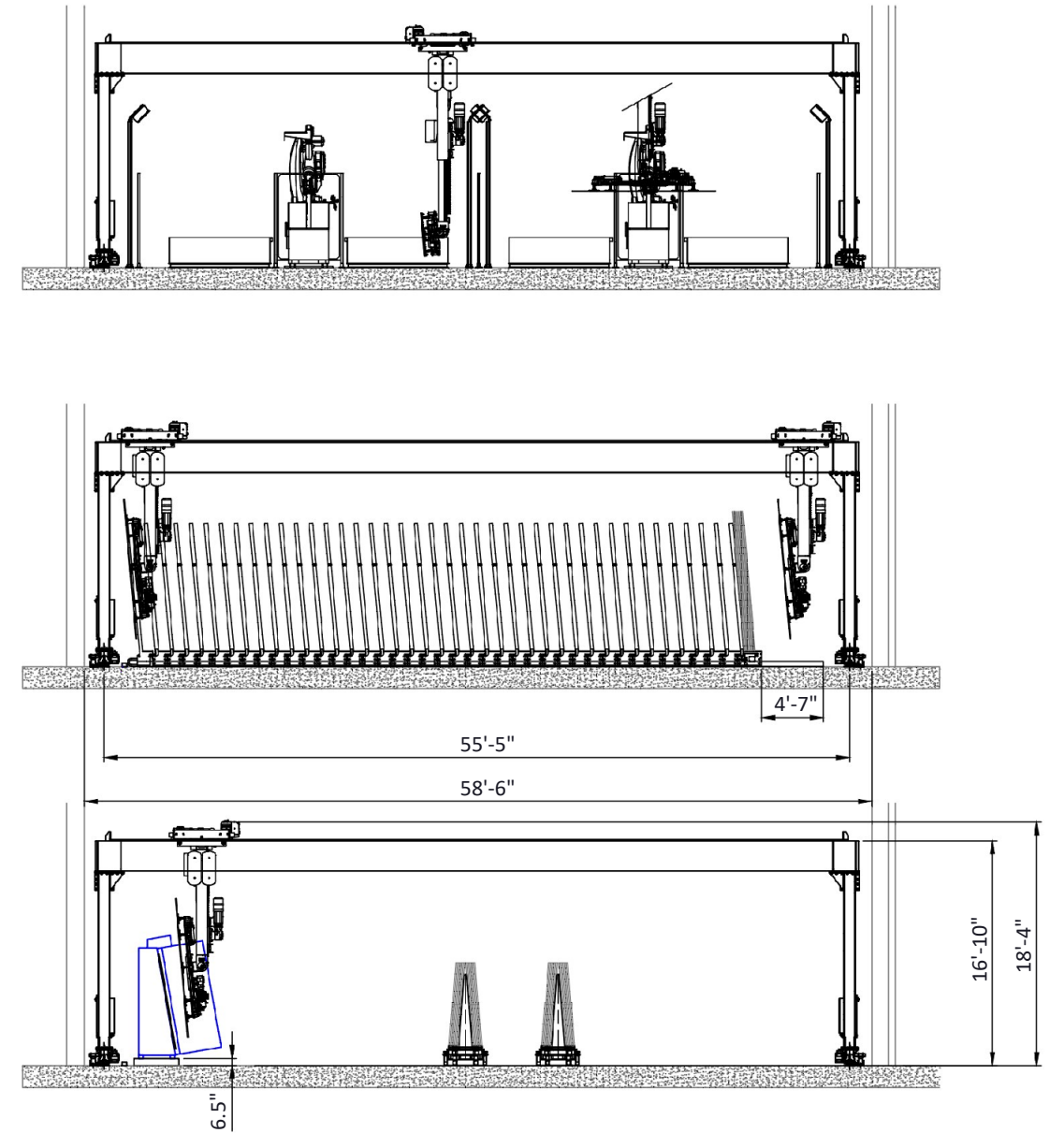

*Automated Slab Handling systems are Fully Customizable

PROPRIETARY AND CONFIDENTIAL.
THE INFORMATION CONTAINED IN THIS
DRAWING IS THE SOLE PROPERTY OF
BACA SYSTEMS.
ANY REPRODUCTION IN PART OR AS A
WHOLE WITHOUT THE WRITTEN PERMISSION
OF BACA SYSTEMS IS PROHIBITED.

BACA SYSTEMS	
DRAWN BY: MN	CHECKED BY: TR
DESC: Automated Slab Handling - Layout	
Job No: -----	REV: L-1.01
SIZE: B	SCALE VARIES
3/15/2024	SHEET 2 OF 4

EXAMPLE 2

TOP VIEW

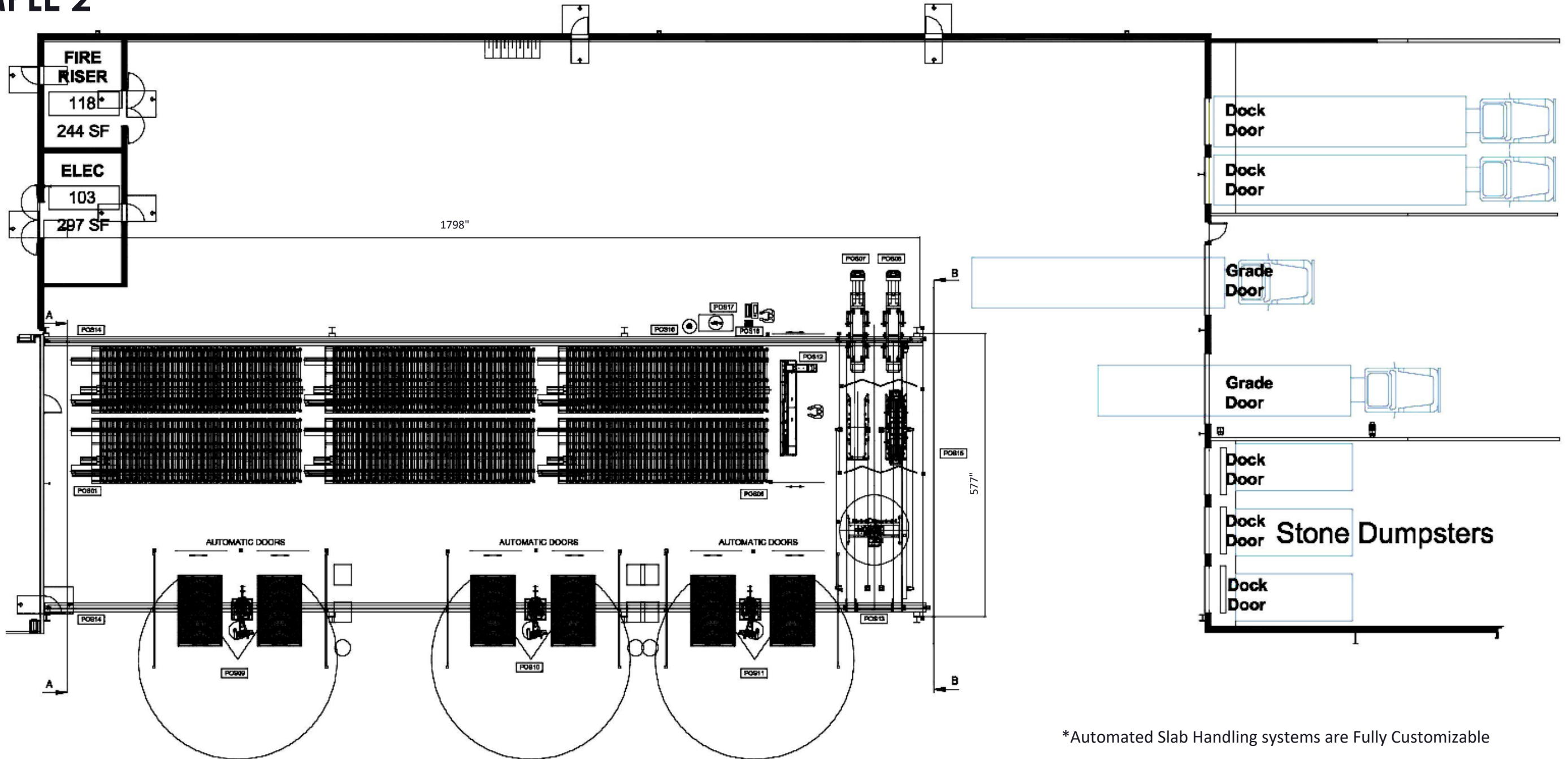

*Automated Slab Handling systems are Fully Customizable

- Pos01 to 06 **N°1 AUTOMATIC CLASSIFIER - 34 POSITIONS - CAPACITY: 206 ton**
 - N°1 FIXED EL. LP230 mm - CAPACITY 6 ton
 - N°32 MOVEABLES EL. LP230 mm - CAPACITY 6 ton
 - N°1 MOTORIZED EL. LP400 mm - CAPACITY 8 ton
- Pos07 to 08 **N°2 LOADING/UNLOADING "A" FRAME STATION**
- Pos09 to 11 **LOADING/UNLOADING HORIZONTAL STATION DUAL TABLE**
- Pos12 **VERTICAL CONVEYOR SCHANER**
- Pos13 **AUTOMATIC CRANE**
- Pos14 **CRANE RAILS**
- Pos15 **SAFETY FENCES**
- Pos16 **ELECTRICAL TRUNKING**
- Pos17 **N°1 CONTROL PANEL**
- Pos18 **N°1 PC STORE PRO**

	Electrical Trunking
	Safety light curtain
	Emergency buttons
	Safety switches
	Safety Locking Device
	Compressed air connection
	Electrical connection



PROPRIETARY AND CONFIDENTIAL. THE INFORMATION CONTAINED IN THIS DRAWING IS THE SOLE PROPERTY OF BACA SYSTEMS. ANY REPRODUCTION IN PART OR AS A WHOLE WITHOUT THE WRITTEN PERMISSION OF BACA SYSTEMS IS PROHIBITED.

DRAWN BY: MN	CHECKED BY: TR
DESC: Automated Slab Handling - Layout	
Job No: -----	REV: L-1.01
SIZE: B	SCALE VARIES
3/15/2024	SHEET 3 OF 4

EXAMPLE 2

SIDE VIEWS

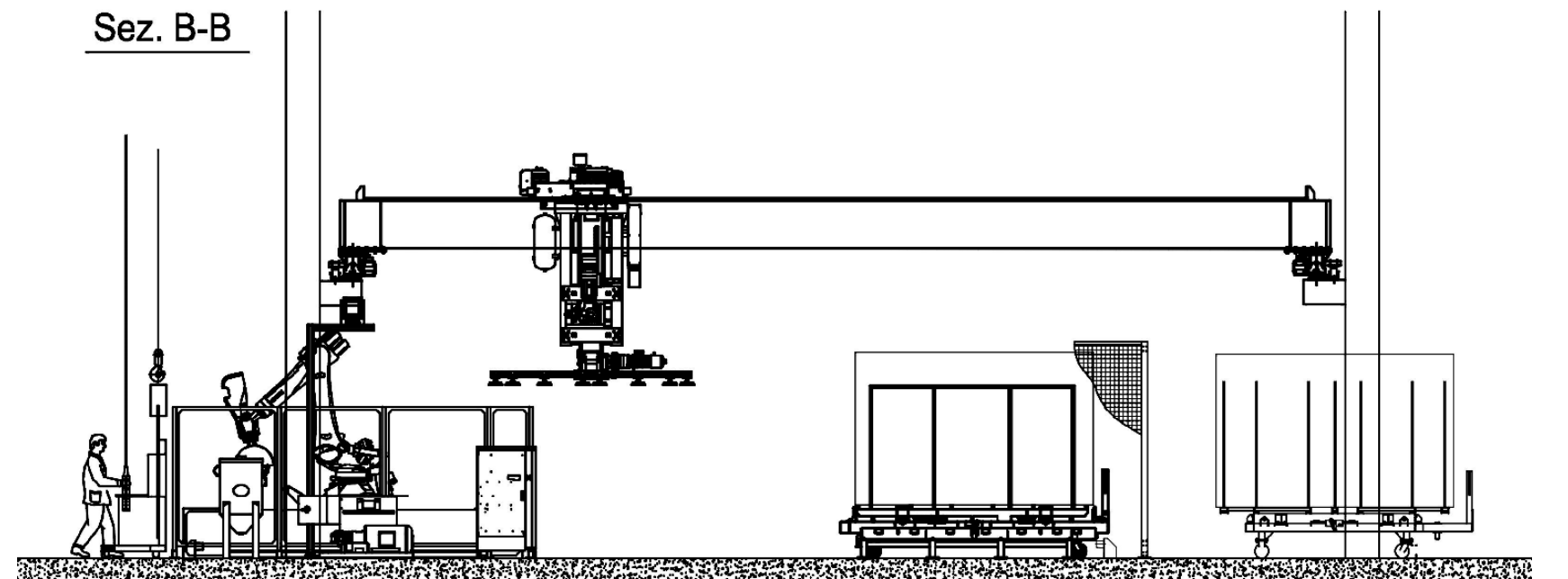
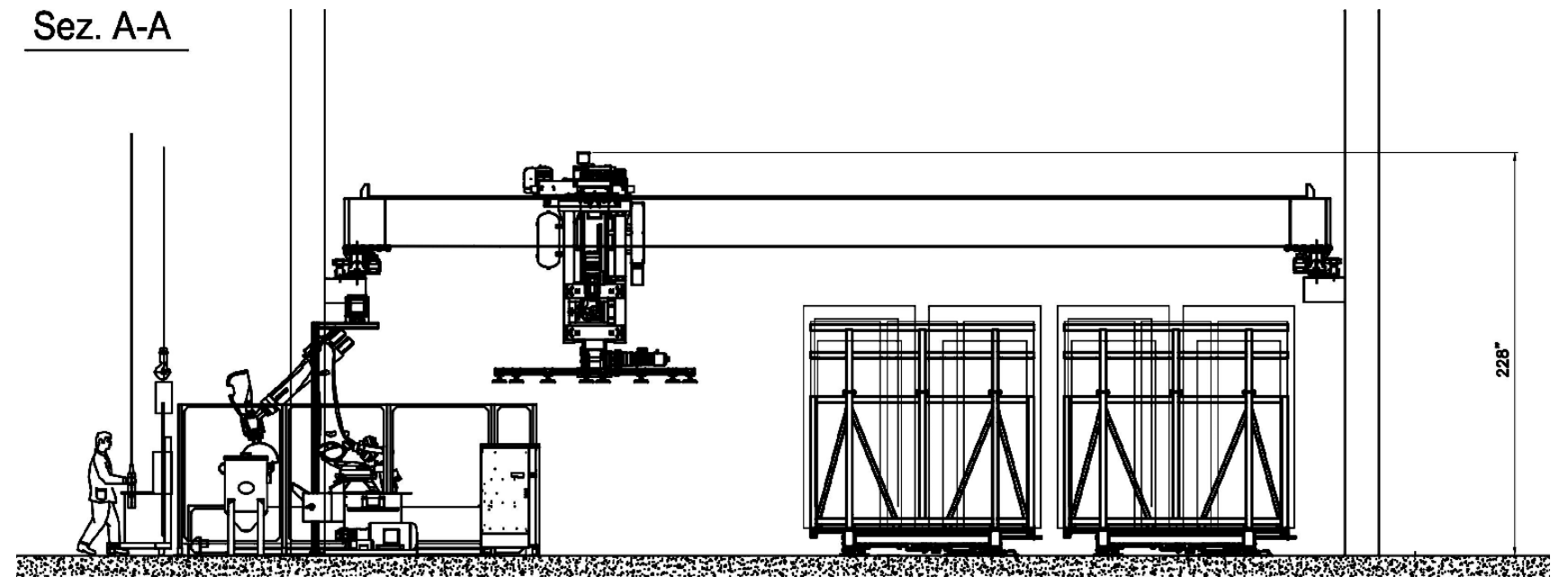
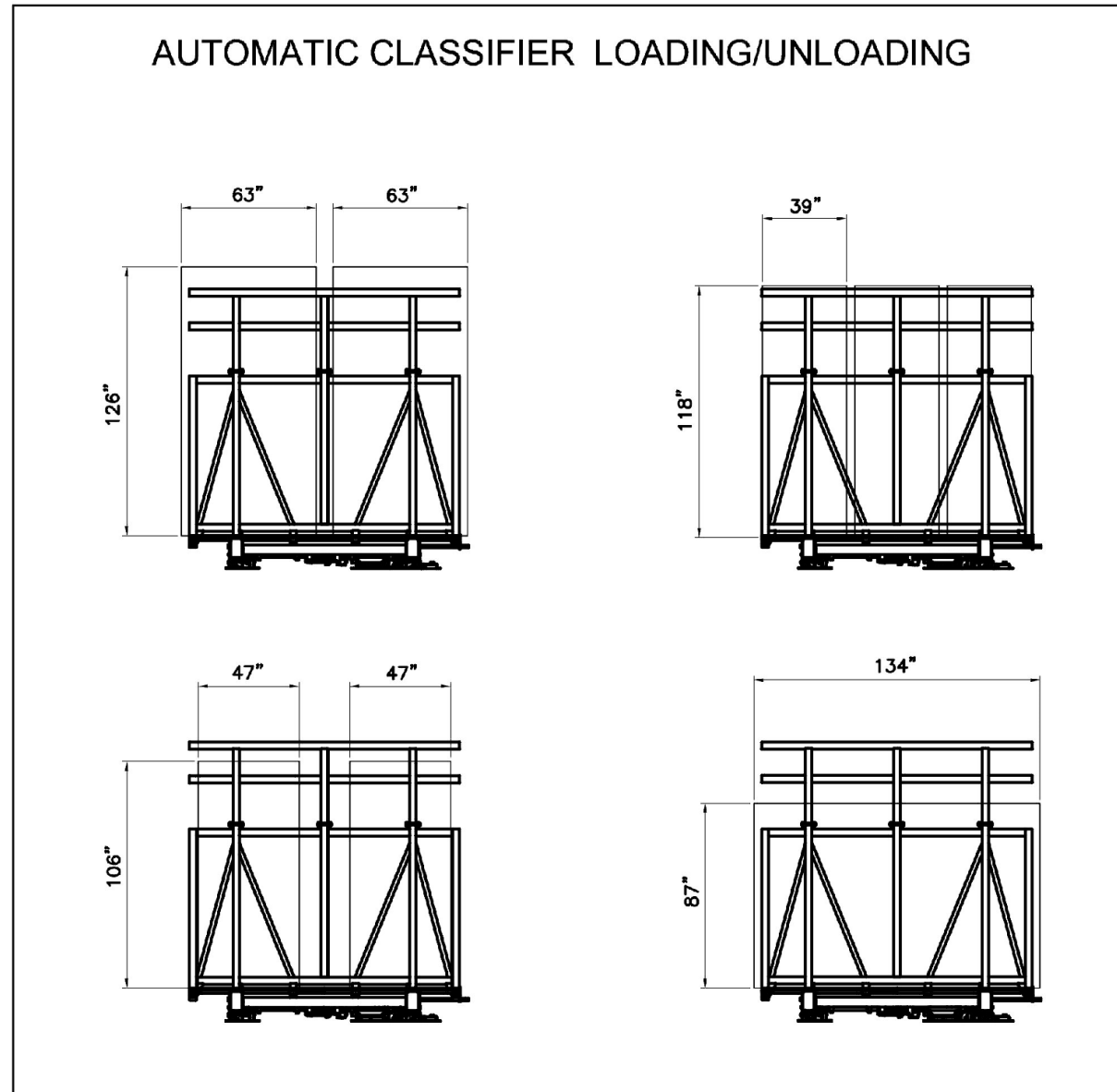

*Automated Slab Handling systems are Fully Customizable



PROPRIETARY AND CONFIDENTIAL.
THE INFORMATION CONTAINED IN THIS
DRAWING IS THE SOLE PROPERTY OF
BACA SYSTEMS.
ANY REPRODUCTION IN PART OR AS A
WHOLE WITHOUT THE WRITTEN PERMISSION
OF BACA SYSTEMS IS PROHIBITED.

DRAWN BY: MN	CHECKED BY: TR
DESC: Automated Slab Handling - Layout	
Job No: -----	REV: L-1.01
SIZE: B SCALE VARIES	3/15/2024 SHEET 4 OF 4